



australian institute of holistic medicine

862 North Lake Road, Cockburn Central, WA, 6164

Phone: 61 8 9417 3553

Fax: 61 8 9417 1881

Website: www.aihm.wa.edu.au

CRICOS Provider Number 01762E

IMPORTANT INFORMATION FOR OVERSEAS APPLICANTS

Please read this document together with the Prospectus for complete information on AIHM. The Prospectus will be posted out to you if you have already supplied your postal address. If you have not, please email your full postal address details to the Registrar at info@aihm.wa.edu.au

If you need any further information, please contact AIHM either by phone during the working hours on 61 8 9417 3553 between 9.00am and 5.00pm. (Western Australian time) Monday to Friday, or send an email to info@aihm.wa.edu.au or a fax to 61 8 9417 1881. You can also access AIHM's website at www.aihm.wa.edu.au and click on the link for International Students for more information.

Overseas applicants should be aware that some of the information provided in the AIHM Prospectus is relevant only to domestic students and the information contained in this document will override that provided in the prospectus. Please read this document in CONJUNCTION with the prospectus. There are also separate application procedures for overseas and local applicants.

All the Advanced Diploma courses offered by the AIHM are registered with the Commonwealth Register of Institutions and Courses for Overseas Students (CRICOS). Accordingly, overseas students may apply for the; Advanced Diploma of Naturopathy, Advanced Diploma of Western Herbal Medicine, Advanced Diploma of Ayurveda or Advanced Diploma of Nutritional Medicine.

To apply for one of our courses, complete and return the application form together with the following documents:

- a) Two recent passport-sized photographs
- b) **Certified** copy of your birth certificate or first few pages of your passport containing your personal information
- c) **Certified** copies of your educational certificates and English Proficiency test results (if applicable)
- d) Two character references obtained from any of the following; a head of school, teacher, police officer, medical practitioner or your health professional, lawyer, responsible officer of a recognised voluntary organisation, head of a government or private establishment.
- e) A non-refundable application fee of AU\$100.00 bank draft made payable to: AIHM

Once we receive your application form, supporting documentation and application fee, we will contact you either to arrange a phone interview or, if you are in Perth, already a personal interview with the Dean of Studies.

If you are successful at the interview, a Letter of Offer (that will include details of the course fees payable and details of the Private Overseas Student Health Cover premium) and a Letter of Acceptance (for you to sign and return) will all be forwarded to you. The Overseas Student Health Cover is compulsory for all overseas applicants.

Upon receipt of your signed Letter of Acceptance and payment of the required course fees, into our trust account, your OSHC premium will be forwarded to Medibank Private. We will then electronically issue a Confirmation of Enrolment to the Australian High Commission Office where you will be lodging your visa application and a copy will be sent to you. You will then be able to proceed with your student visa application.

Introduction to the City of Perth in the State of Western Australia

Perth is the capital of Western Australia and has a population of more than 1,400,000, which makes up two-thirds of the population of the state. It is the education hub of Western Australia with five major universities and more than 70,000 university students.

The people of Perth enjoy a warm, sunny climate with an average rainfall of 880mm. On average there are 7.9 hours of sunshine daily, with daytime temperatures ranging from a maximum of 40 degrees in the summer months – December, January and February – down to 19 degrees in the winter months – June, July and August.

Perth is a multicultural society with people from many ethnic backgrounds including Chinese, Greek, Italian, Sri Lankan, Vietnamese and Indian, together with those of European descent.

Situated on the banks of the Swan River, Perth is well linked to the rest of the world via excellent communication and transport systems. Most major businesses and government offices are situated in the inner city, while most residents live in the suburbs and commute by car, train or bus to the city or to other suburbs for work. The Institute's campus is approximately 30 minutes south of Perth's CBD and is accessible by public transport.

Introduction to the Australian Institute of Holistic Medicine

AIHM is a Registered Training Organisation located in tranquil settings of Cockburn Central, WA. AIHM was established in 1992 and gained CRICOS registration in 1997. (CRICOS No.01762E).

AIHM offers Pleasant study environment with a balance between modern medical sciences and traditional healing arts, in a relaxed setting where you will enjoy your learning experience.

Facilities

AIHM training facilities are located at:
862 Northlake Rd, Cockburn Central, WA 6164

The facilities at AIHM include air-conditioned and heated classrooms with internet and computer access areas available for enrolled students.

All training is conducted with ample tools and equipment available to students. Supplementary research materials and resources are within easy access.

AIHM operates with a fully operational clinic. All of the rooms at the clinic have resources required to operate in the Natural Medicine industry.

This includes:

Anatomical models,
Educational materials

As well as all towels, oil and needles required for client sessions.

The clinic has its own dispensary where herbal remedies are manufactured.

The dispensary has all the raw materials, oils, books, training manuals and software required to meet the needs of our clients.

AIHM's classrooms are all equipped with video/DVD players and TV's, anatomical models and educational material.

There is a reference library on site for students to use and borrow selected books from. The library also has internet access.

Course Fees, Content , Duration, Modes of Study and Assessment

AIHM provides the following courses, with a combination of classroom and workplace training approaches. Assessments include written tests, assignments, observation of workplace and simulated tasks. (Duration of each course is listed below)

Students study competency based training and assessment methods and will be assessed according to established industry standards that will equip the student with the essential skills and knowledge to gain a firm footing in their chosen industry area.

Students who successfully complete their course will be awarded with qualifications that are nationally recognized

The following qualifications are offered by AIHM for international students.

- Advanced Diploma of Naturopathy – 104 weeks
 - Tuition Fees \$26609
 - Resource fees \$1405
 - Uniform fees \$95
- Advanced Diploma of Western Herbal Medicine - 104 weeks
 - Tuition Fees \$22473
 - Resource fees \$1486
 - Uniform fees \$95
- Advanced Diploma of Nutritional Medicine - 104 weeks
 - Tuition Fees \$23969
 - Resource fees \$1442
 - Uniform fees \$95
- Advanced Diploma of Ayurveda - 104 weeks
 - Tuition Fees \$24596
 - Resource fees \$816
 - Uniform fees \$95

Resource fees include compulsory textbooks.

All fees listed may change from time to time. All students currently enrolled will be informed at least 12 weeks before such changes are implemented.

Refund Policy for International Students

AIHM will provide a total refund of tuition fees paid in advance where a course place is no longer available or a Visa has been denied, less the application fee. Additionally AIHM will provide a total refund of fees paid in advance or for tuition already received less the application fee where:

- a) the course does not start on the agreed starting day.
- b) the course ceases to be provided at any time after it starts but before it is completed; or
- c) the course is not provided in full to the student because a sanction has been imposed on the registered provider under part 6 (ESOS Act)

Courses longer in duration than 10 weeks

Where a written application is received for a Course Money Refund:

- AIHM will provide a total refund of course money paid in advance where a Visa has been denied minus an administration fee of \$150
- AIHM will provide a full refund of course money paid in advance, where enrolling students provide more than 10 weeks written notice of their intention to withdraw from the course prior to the course commencement. The refund will be less the maximum of 10% or \$1000, whichever is the lesser, for administrative expenses.
- AIHM will provide a partial refund of course money paid in advance, where enrolling students provide more than 4 weeks and up to 10 weeks written notice of their intention to withdraw from the course prior to the course commencement. The refund will be 70% of a term's fee less the maximum of 10% or \$1000, whichever is the lesser, for administrative expenses.
- AIHM will provide a partial refund of course money paid in advance, where enrolling students provide less than 4 weeks written notice of their intention to withdraw from the course prior to the course commencement. The refund will be 40% of a term's fee, less the maximum of 10% or \$1000, whichever is the lesser, for administrative expenses.
- AIHM will provide a partial refund to students who withdraw after the commencement of the course up to the first 4 weeks. The refund shall be 30 % of a term's fee, less the maximum of 10% or \$1000, whichever is the lesser, for administrative expenses.
- AIHM will not refund where a student has withdrawn from the course after the 4th week of the course.
- A student, who has paid for more than two terms in advance and withdraws during the term and more than four weeks before the commencement of the following term, will receive no refund of fees for the current term and at least 70% of the following term's fees and a full refund of fees paid for any subsequent term.
- Should AIHM Management withdraw its offer or fails to provide the program offered or terminates its course delivery before or after term/Education Service commences AIHM will provide a full refund of course money.
- Should AIHM Management withdraw a student from a Course because the student has seriously breached international student visa conditions or a provider's rules, no refund of the current term's fees and 40% of fees applicable to a subsequent term and a full refund of fees paid for any subsequent terms.

Refund Procedures

Where a student believes that they have grounds for a course fee refund, students should:

- Submit a written request for course fee refund to the Overseas Contact Officer (Registrar)
- State valid reasons for their course refund application.
- Allow 7 days for the application to be processed by AIHM Management
- Recognise that AIHM's Management refund policy and the availability of complaints and appeals processes, does not remove the right of the student to take action under Australia's consumer protection laws.
- When receiving a written course fee refund application the Overseas Contact Officer shall:
 - Present the application to AIHM management
 - Provide the student in writing the resulting decision of AIHM Management.
 - Advise the student of their right to appeal the decision of AIHM Management.

Enrolment deferment, suspension or cancellation

AIHM Management and staff are committed to assessing and recording all deferments, suspensions or cancellations of study, ensuring that students within the process are informed of their rights and provided with due care and where relevant opportunities for appeal. AIHM management will only suspend or defer enrolment on the grounds of –

- a. compassionate and compelling circumstances.
- b. misbehaviour by the student.

Deferment Procedure

The Overseas Student Contact Officer must:

- Respond to each request for course study deferment by requiring a written request from the student that identifies the reason for which they require a course of study deferment.
- On receiving a request for course study deferment ensure that the student is aware of AIHM's appeals process.
- Notify the AIHM management staff of the pending application providing a copy of the written request for consideration in the next AIHM management meeting.

The AIHM Management meeting shall ensure that the deferment request is considered:

- On the grounds of the written request and ensuring that compassionate and compelling circumstances (which are beyond control of the student) are assessed where evidence of their validity is provided.

These circumstances may include:

- serious illness or injury, where a medical certificate states that the student was unable to attend classes
- bereavement of close family members such as parents or grandparents (Where possible a death certificate should be provided)
- major political upheaval or natural disaster in the home country requiring emergency travel and this has impacted on the student's studies
- a traumatic experience which could include: involvement in, or witnessing of a serious accident; or witnessing or being the victim of a serious crime (these cases should be supported by police or psychologists' reports)
- where the registered provider was unable to offer a pre-requisite unit; or
- Inability to begin study on the course commencement date due to delay in receiving a student visa.

Deferment Request Responses

Following the AIHM's management meeting where the student's request is considered the Overseas Student Contact Officer shall :

- Ensure that the student is informed of the resulting decision of the AIHM Management meeting in a timely manner.
- Ensure that all records of the request and supporting evidence are copied and placed on the students file.
- Maintain the enrolment of the student should the student seek an appeal through the internal or independent adjudicator appeals process.
- Ensure that the student is advised to contact the office of DIAC so that they are informed as to the impact of their deferment on their existing student visa.
- Ensure that the student is advised that their course fees may also be affected by a deferment.
- Report the student's change of enrolment to DIAC via PRISMS as soon as practicable after a decision on deferment has been finalized and recorded by AIHM management.
- Respond to advice from DIAC concerning the issuance of a new ECOE through PRISMS.

Suspension or Cancellation Procedure

Where a student's conduct has been found to violate AIHM's rules of enrolment and where warning has been provided the Overseas Student Contact Officer shall:

- Inform the student that their misconduct has resulted in a report being made to AIHM management.
- Ensure that the student is aware that they may access AIHM's internal appeals process and independent adjudicator.
- Inform the student should a decision to suspend or cancel their enrolment is made by AIHM management, that they have 20 working days to appeal following the decision. (AIHM management has 10 days to commence the process after the appeal is received)
- Provide a written report to the next AIHM management meeting detailing the misconduct offense and the manner in which their conduct has been dealt with thus far (the report should detail dates times and persons involved).

Suspension or Cancellation Responses

In receiving a report of misconduct AIHM management shall:

- Validate the actions of all staff involved seeking further advice, verbal or written.
- Where necessary, seek further advice from the student or students involved maintaining an unbiased approach to the student or students involved.
- Decide whether an enrolment suspension or enrolment cancellation is warranted.
- Ensure that in upholding the decision to suspend or cancel the student's enrolment, the student is informed in writing, stating the reason for AIHM Managements' decision and re affirming the student right to the internal appeals process and independent adjudicator within 20 working days.
- Maintain the student's enrolment if the student chooses to access AIHM's internal appeals process except in the case of extenuating circumstances (definition follows).
- Only report the student's change in enrolment to DIAC via PRISMS if the student does not appeal the decision or if the student requests an independent adjudicator.
- Report the student's change in enrolment to DIAC via PRISMS before the outcome of any internal/external appeals process if extenuating circumstances exist.

Extenuating circumstances' relating to the welfare of the student may include, but are not limited to the following. The student:

- refuses to maintain approved care arrangements (only for students under 18 years of age);
- is missing;
- has medical concerns, severe depression or psychological issues which lead the provider to fear for the student's wellbeing;
- has engaged or threatens to engage in behaviour that is reasonably believed to endanger the student or others; or
- is at risk of committing a criminal offence.

Student Transfer

The enrolling staff member shall not knowingly enrol a student who has not completed six months of their principal course and will only enrol an international student on a student visa in specific circumstances when transferring from another provider.

Course Enrolment Transfer from another Provider

On receipt of an application for transfer of enrolment the enrolling staff member shall:

- Ensure that the student has completed at least six months of his or her principal course of study unless:
 - the original registered provider has ceased to be registered or the course has ceased to be registered.
 - the original registered provider has provided a written letter of release.
 - the original registered provider has had a sanction imposed on its registration by the Australian Government or state or territory government that prevents the student from continuing his or her principal course,
 - any government sponsor of the student considers the change to be in the student's best interest and has provided written support for that change.
 - any government sponsor of the student deems that a transfer is in the student's best interest and supports the transfer request in writing.
 - Meets the entry requirements – *i.e.* is of 18 years or more.

Course Enrolment Transfer to another Provider

When a student requests a transfer of their enrolment to another registered provider the enrolling staff member shall:

- Provide the student with advice on AIHM's procedures for applying for course transfer, including the need to formalize the request in writing stating the reasons for which they desire to transfer their course enrolment to another provider.
- Advise the student that their request may take as long as, but will not extend past a 7-day assessment period.
- Refuse a transfer to another course offered by a registered provider except where reasonable circumstances or compassionate grounds can be established, such as undue hardship or sickness in the family that prevents travel to or from the course provider's location of training.
- Provide a letter of release only after the student has provided a letter indicating a valid enrolment offer from another registered provider.
- Issue a [letter of release](#) at no charge to the student informing the student that they should contact DIAC for further information concerning their student visa requirements. Refuse an application for transfer where a transfer is considered detrimental to the student's academic progress.
- Provide a [release refusal letter](#) with written reasons outlining the reasons why the students request for transfer has been refused.
- Provide advice of AIHM's complaints and appeals process should a release refusal letter be issued.
- Ensure that all records associated with a transfer application are filed within AIHM's student records system.

Complaints and Appeals

Students enrolled at AIHM have ongoing access to a Complaints and Appeals procedure which features both an Internal and if necessary an External process

Internal Process

The features of the AIHM Complaints and Appeals Process include.

- written records of all complaints and appeals
- registering complaints and appeals are at no or minimal cost to the student.
- allowance of a support person at any complaints or appeals meetings
- written statements detailing complaint and appeal outcomes
- resolutions to complaints and appeals are acted on promptly.

Anytime a student disagrees with a decision made by AIHM management or staff, they may submit a complaint in writing. A decision by AIHM management concerning the students appeal outcomes will be provided to the student in writing.

If overseas student wants to complain or appeal the decision, they can contact the Overseas Students Ombudsman. The overseas students Ombudsman is free and independent. To find out more students can log in to www.oso.gov.au or phone 1300 362 072

The Overseas Students Ombudsman investigates complaints about problems that overseas students or intending overseas students may have with private education and training in Australia.

The legal basis for the Ombudsman role is the *Education Services for Overseas Students (ESOS) Legislation Amendment Act 2011*, passed by the Australian Parliament on 21 March 2011.

The Ombudsman also provides information about best practice complaints handling to help private education providers manage internal complaints effectively and publishes reports on problems and broader issues in international education identified through investigations.

The Ombudsman:

- provides a free service

- is independent and impartial, and does not represent either overseas students or private education providers
- can make recommendations arising out of investigations
- is a function of the Commonwealth Ombudsman.

External Process

If student disagrees with appeal decisions of AIHM Management they may have access to an External Independent Adjudicator, ACPET. (please refer to the student handbook for further advice)

Department of Education Employment and Workplace Relations

Please find the enclosed information that explains your rights as a student studying in Australia under the Education Services for Overseas Students Act 2000. (This prospectus should be supplied only when it is accompanied by the ESOS framework information) You will need to indicate that you have read this information before signing your Letter of offer.

The AIHM website also contains a link to the ESOS framework.

Please visit <http://www.aihm.wa.edu.au/overseas-students.html> to access the ESOS framework.

Living in Perth

The following information provides an indication of living expenses associated with residence in Perth

Single person costs of living

(Rental Accommodation (unit/villa):

- 1 Bedroom AUD 200-\$250 pw
- 2 Bedroom AUD 300-\$340 pw

(Dependent on whether furnished or unfurnished)

Electricity	AUD 25 pw
Telephone (Landline)	AUD 10-15 pw
Medical	AUD 7 pw (based on Medibank current rates)
Public Transport	AUD 25 pw
Food	AUD 60 pw
Laundry	AUD 12 pw
Other	AUD 50
(Clothing, Toiletries, entertainment)	

Budget per week for a single person: AUD 400 – AUD 500

Renting – Can range from \$300 - \$500 plus per week depending on the area and location. One website that has been used previously by several overseas students looking for shared accommodation is

<http://au.easyroommate.com>

Family of 4 Costs of living

Rent	AUD 300 – AUD 450 Approx
Other Housing costs	AUD 119
Schooling	AUD 108
Cars	AUD 125
Food	AUD 250
Sport and Recreation	AUD 40

Approx budget for a family of 4: \$1100.00 pw

Education

School is compulsory for all children aged between five and seventeen years. These ages may vary slightly in some states. The government provides public schools. Churches and other groups provide private schooling. You will need to check with the Department of Education of WA for their criteria and assessment for their fees in a public school. Fees are also payable for private schooling.

Note: Students holding temporary visas may be required to pay full school fees. Check with individual schools for details.

Student Support Services

Prior to course commencement AIHM Staff will provide an Orientation Program that is designed to provide information concerning the course you are enrolling in. AIHM Staff remain available for any concerns that you may have with regard to study or education information.

Additional support services are available by contacting the Registrar. The Registrar is available to discuss and provide assistance in all areas of your welfare including your accommodation needs and health cover.

Students with visa enquiries will be directed to the Department of Education, Employment and Workplace Relations (DEEWR) and the Dept. of Immigration and Citizenship (DIAC).

Assistance & Essential Service

Ambulance, Fire and Police, EMERGENCY ONLY 000

Police – Non emergency – 132577

Fremantle Hospital Accident & Emergency

1/3 Alma St

Fremantle Western Australia 6160

Health Services

Gateways Dental Centre - (08) 9498 6000

Amcal Pharmacy – (08) 9498 5977

Thompson's lake medical centre – (08) 9414 9188

Support Services

Alcohol & Drug Information Services 9442-5000 (Confidential counselling and information)

Lifeline 13 11 14 (Suicide Counselling)

Men's Domestic Violence Helpline 9223-1199

Sexual Assault Resource Centre Crisis Line 9340-1828 Or FREECALL 1800-199-888

Legal Advice

Legal Aid Commission of WA
55 St. Georges Terrace, Perth
Info line 1300-650-579

Citizens Advice Bureau
22 Barrack Street
Perth
Ph: 9221-5711

Law Society of WA
Ph: 9322-7877

Multicultural Services Centre WA
20 View Street
North Perth
Ph: 9328-2699

ENGLISH PROFICIENCY

All courses at the AIHM are delivered in English. Students are therefore required to have a high level of proficiency in written and oral English. Students whose native, or first, language is not English will need to provide the results of a TOEFL or IELTS (or the equivalent) examination prior to enrolment at AIHM. The minimum requirement is a TOEFL score of 550 or an IELTS score of 6.

For information about where you can take an IELTS test please refer to their website www.ielts.org and search by selecting the country you wish to take the test in. This will give you the contact details and address.

For information regarding the TOEFL tests please check their website www.ets.org

We may not require test results for the following:

- Non native speakers who hold degrees or diplomas from postsecondary institutions in English-speaking countries (e.g., the United States, Canada, England, Ireland, Australia, New Zealand)
- Non native speakers who have successfully completed at least a two-year course of study in which English was the language of instruction
- Transfer students from institutions in the United States or Canada whose academic course work was favourably evaluated in relation to its demands and duration.
- Non native speakers who have taken the TOEFL test within the past two years
- Non native speakers who have successfully pursued academic work at schools where English was the language of instruction in an English-speaking country for a specified period, generally two years.

However, the final decision on acceptance of any applicant will be based on an interview with the Dean of Studies either by telephone or in person.

If student faces some difficulties with the level of English proficiency required after commencement of the course, the student is encouraged to speak initially to the Registrar or the Dean of Studies who can direct them for external assistance. There are several educational facilities located in Perth offering intensive English language programs and these are listed in the Yellow Pages telephone directory under Language Instruction. These facilities should be contacted directly in relation to the fees charged and the course content.

RECOGNITION OF PRIOR LEARNING

Where the student has received qualifications, either from an overseas facility or another Australian educational facility, or can demonstrate their competency in the subject matter through vocational life experience, they are eligible to enrol in a AIHM RPL unit within the course of study that enables a comprehensive skills analysis and competency assessment to occur.

In case of overseas student if the RPL is granted for any unit/s which leads to a shortening of the student's course, the following is done:

- a. if the RPL is granted before the student visa grant, the actual net course duration (as reduced by RPL) in the confirmation of enrolment is issued for that student for that course, or
- b. if the RPL is granted after the student visa grant, report the change of course duration via PRISMS under section 19 of the ESOS Act.

STUDENT SUPPORT

Students are advised to contact the Registrar in relation to any problems or if they need any advice or assistance in the following areas:

- Personal, emotional, religious and cultural issues.
- Study skills.
- Education information.
- Application for further studies.
- Student's health cover and other related issues

The Registrar will be able make the appropriate referrals and/or arrangements.

ORIENTATION PROGRAM

The AIHM provides an orientation program for all new international students that may include airport pick up, assistance in finding accommodation, a city tour, and visits to local libraries and other important centres.

The Orientation session is designed to ensure that the students are familiar with all the AIHM Rules & Regulations and their obligations under their Visa conditions as well as becoming familiar with the AIHM's facilities.

COMPULSORY OVERSEAS STUDENT HEALTH COVER

The AIHM will arrange this compulsory Health Insurance cover through Medibank Private. Legislation requires that all international students are covered for the duration of their visa. AIHM will organise your OSHC cover for the whole length of your course.

A "Single" policy will cover just the student. A "Family" policy will cover the student, their spouse and dependent children, less than 18 years of age, if they are living in Australia with the student. If other members of the student's family (for example, a brother or sister) come to stay in Australia with them, they cannot be covered by Overseas Student Health Cover, but they should contact Medibank Private separately to take out their own policy.

The premium for singles cover will be detailed in the Letter of Offer. Once the premium is received by AIHM, we will issue a letter to Medibank Private and forward the premium to them. As a guide, single cover for the Advanced Diploma courses which run for two years is \$996.00. This is subject to change and the current cost will be included in the offer letter.

For more information about services provided by Medibank Private please check their website at www.medibankprivate.com.au and click on the Overseas Students section.

CHANGE OF ADDRESS

All international students have the requirement of notifying AIHM within five working days of any change of address details. Failure to do so could affect the status of the student visa.

TESTIMONIALS FROM OVERSEAS STUDENTS OF THE AIHM

Here are some short testimonials/comments from overseas students at the AIHM.

“Coming from the French university education system, studying at AIHM is a bit of a treat really!! Small class effectives, non-competitive atmosphere, co-operation between students, communication between students and teachers/staff, flexibility, huge attention towards student's needs and feedback, the integration of both physical and spiritual approach, a good balance between the theoretical and practical teachings and the positivity ...

I am truly more than satisfied by what I am being offered at AIHM :-)”

Claire Marque 2006.
France

“I believe that everything happens for a reason. When I initially decided to come and study in Australia, I had done some research and looked at several schools. However, I was drawn to the AIHM, based on what I read and saw on their website, the positive report that I received from a friend of mine who attended the free info night presented by the school, and my personal interaction with the staff via email and phone conversations prior to moving to Australia from Hawaii. My experience here at AIHM continues to be a positive one. I love being able to take what I have learned in class and be able to apply it to my life almost immediately; for example, I have never been one to meditate, however from doing brief meditation with Dr. Sam in the morning, before class, I have learned to love it. What a difference meditating has made in my life. The small class size is great; it makes it easier to communicate with the other students and the instructor. I don't feel like I am just a number. Being a Remedial Massage student at AIHM, I know more about the human body than when I first started, however more than that, I know that I am a better person today. My life has been richly blessed by the students, staff, instructors and clients I have met at school.”

Greta Balabagno 2006
Hawaii

“I came from Brazil and the reason why I chose AIHM is because of the personal treatment I got, since the first contact I had with AIHM. I have looked for many courses not only in Australia but in Europe, America, and many parts of the world. The treatment I got from AIHM right from the beginning was the best and I chose AIHM as a result. I have made very good friends at the institute and I am truly very thankful for everything that the institute has given me to realise a greater meaning in my life.”

Marcello Nose 2011
Brazil

“I found AIHM to be very personal and it helped me a lot as an international student from the beginning. I always felt very supported by everyone at the institute.”

Madou Eppenga 2011
Denmark

What are some of the natural therapies available to you?

Naturopathy

Naturopathy is based on the belief that the body has the ability to heal itself. Although the fundamentals of naturopathy were well known to human beings it was only established in the late 1890s by German physician Benedict Lust. The fundamentals of naturopathy include an appreciation of the body's innate ability to heal itself given the right circumstances, treating the whole person, treating the cause of the problem, doing no harm, allowing the patients to take responsibility, allowing the practitioner to become the teacher, incorporating lifestyle changes and practising the belief that prevention is better than the cure.

Nutritional medicine

What we eat and how we eat has an enormous impact on our health and well being. About 70 per cent of diseases leading to ill health and premature death are nutritionally oriented. Hippocrates, the father of medicine, said we should “consider food as medicine”. Nutritional medicine explores contemporary and traditional nutritional principles and practices that will lead to a healthy and vibrant life. While many nutritional practices focus on biochemical actions of nutrients, traditional nutritional medicine contemplates the quantum energetic aspects and food qualities that will suit individual constitutions.

Herbal medicine

Herbal Medicine is considered to be the oldest medicine on our planet and is still used to promote healing and to maintain good health by more than 75 per cent of the world's population. Unlike pharmaceutically synthesised drugs, herbalists use the whole plant, which has the synergistic effects of many ingredients that are found on the plant. The aim of herbal medicine is to restore the body's ability to heal itself and maintain good health. Herbal or botanical products can be prepared as tinctures, capsules, liquid or solid extracts, tablets, lozenges, teas, decoctions, poultices, vapour treatments, compresses, bark products or local topical applications.

Ayurveda

This is an ancient traditional vedic system of medicine that is more than 5000 years old. The word ayurveda means the science of life. Ayurveda is considered to be a complete system of medicine, which focuses treatment and prevents illnesses by incorporating basic life principles. Ayurveda recognises that the human body is a combination of tridoshas – vata, pitta and kapha – which are also known as biological humours and each individual has tridoshas in unique combinations within them. Imbalances of tridoshas can lead to diseases. Some main treatment modalities of ayurveda include lifestyle changes like balanced diet, exercise, detoxification (panchakarma), herbal medicine, aromatherapy, massage, counselling, yoga and meditation.

COURSES FOR INTERNATIONAL STUDENTS

Career guides

The following pages show recommended study paths for various careers in Natural Medicine

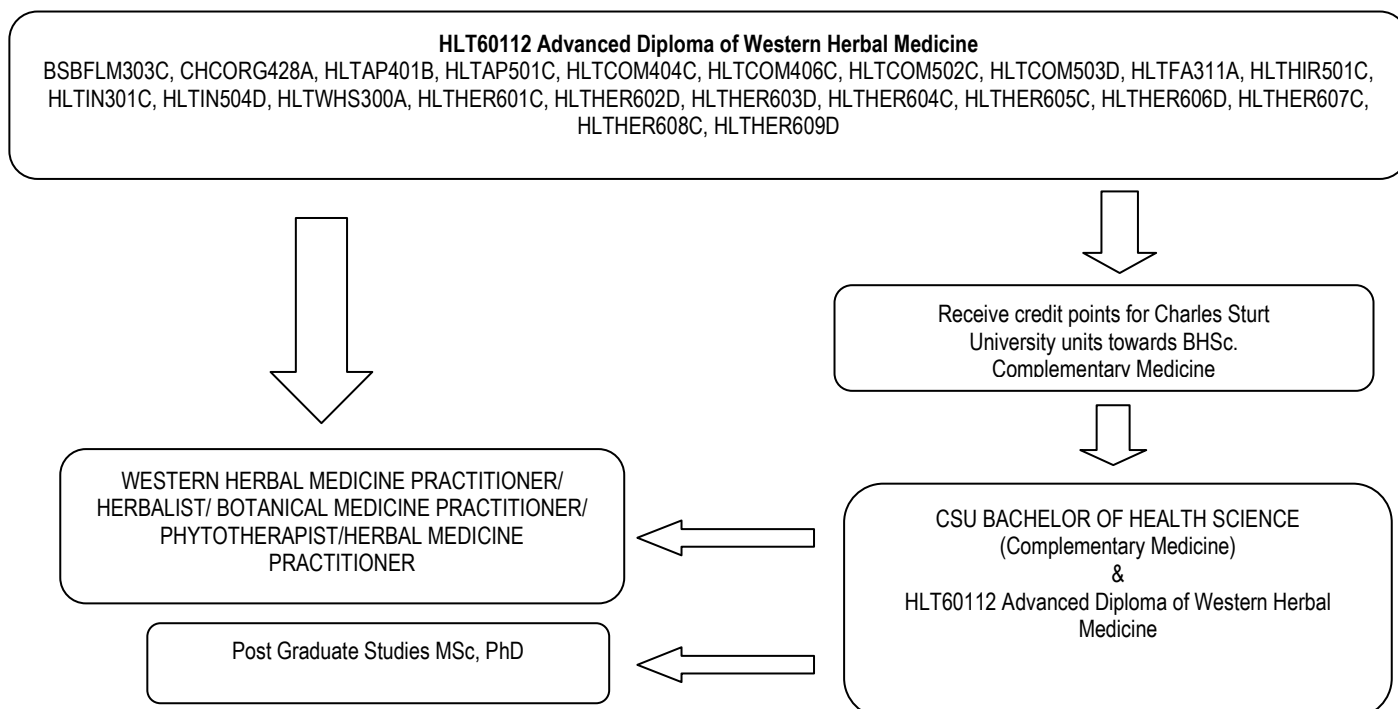
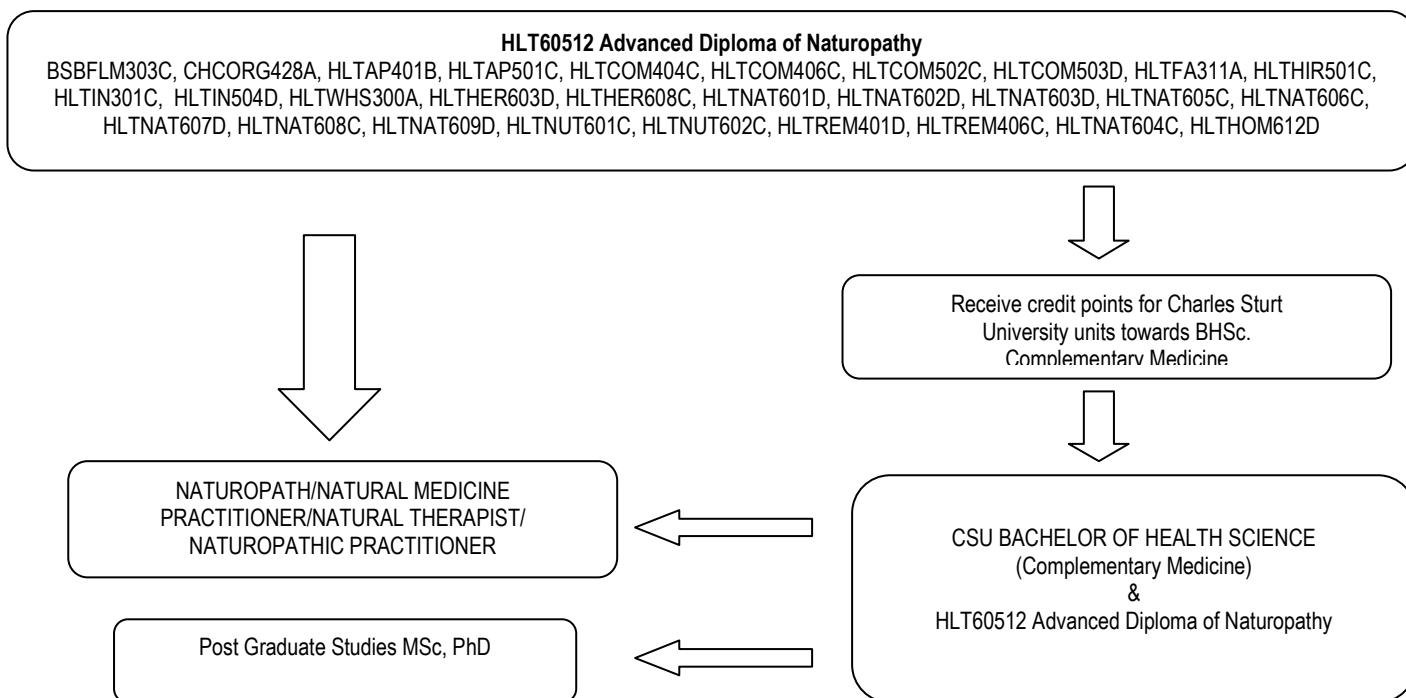

HLT61012 Advanced Diploma of Nutritional Medicine
 BSBFLM303C, CHCORG428A, HLTAP401B, HLTAP501C, HLTCOM404C, HLTCOM406C, HLTCOM502C, HLTCOM503D, HLTF311A, HLTHIR501C, HLTIN301C, HLTIN50D, HLTWHS300A, HLTNUT601C, HLTNUT603B, HLTNUT604C, HLTNUT605B, HLTNUT606B, HLTNUT607C, HLTNUT608C, HLTNUT609C, HLTNUT610B, HLTHIR403C, HLTHIR404D

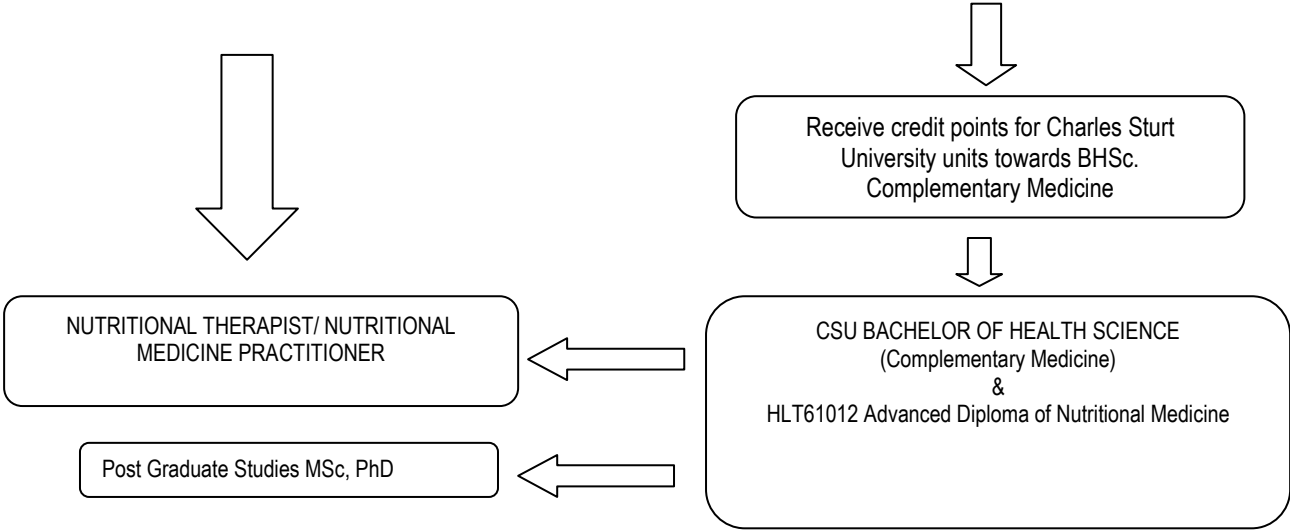

HLT60712 Advanced Diploma of Ayurveda
 BSBFLM303C, CHCORG428A, HLTAP401B, HLTAP501C, HLTCOM404C, HLTCOM406C, HLTCOM502C, HLTCOM503D, HLTF311A, HLTHIR501C, HLTIN301C, HLTIN504D, HLTWHS300A, HLTAYV404D, HLAYV412C, HLTAYV601C, HLTAYV602C, HLTAYV603D, HLTAYV605D, HLTAYV607C, HLTAYV608C, HLTAYV609C, HLTAYV610C, HLTAYV611C, HLTAYV613D, HLTAYV615C

